

NEW

宏发电气 (HONGFA) 49FD



■ 特性 / Features

- 薄式(宽5mm)经济型功率继电器
- 耐浪涌电压4,000V、耐电压AC 2,000V(线圈和触电之间)的薄式松下(PANASONIC) PA 继电器
- Switching范围广泛的高灵敏度继电器
100 μ S, 100mV DC-5A 250VAC、5A 30VDC
- 采用接触可靠性优异的触点材料
- 采用镀金银合金材料触点, 从而接触非常可开, 耐久性优异
原产地 (Made in China)

■ Specifications(at 20°C)

项目	规格
Arrangement	1a
Contact material	Gold clad silver alloy
Initial contact resistance. max.	30m Ω 以下
Nominal switching current	5A
Nominal switching capacity	5A 250VAC, 5A 30VDC
Min. switching capacity	100 μ A, 100mV DC
Max. switching power	700VA, 90W
Max. switching voltage	250V AC, 110V DC
Nominal operating power	180mW
Expected life(Mechanical)	2,000万次以上
Expected life(Electrical)	10万次以上(3A 250VAC、3A 30VDC)

■ Characteristics

项目	规格	
Max. operating speed	20CPM	
Initial Insulation resistance	Min. 1,000M Ω (500V DC)	
Initial Breakdown voltage(1min)	Between open contacts	1,000V
	Between contact and coil	2,000V
Surge voltage	4,000V	
Operate time	约6ms以下	
Release time	约3ms以下	

■ Coil data

Nominal voltage	Pick-up voltage	Drop-out voltage
24V DC	16.8V DC	1.2V DC

Coil resistance	Nominal operating power
3,200 Ω	180mW

公司电子样本浏览手机网站

www.wzjh.cc

了解公司最新动态及相关信息与成功应用情况



微信二维码

www.wzjh.cc

扫一扫, 更精彩……



1. Max. switching capacity

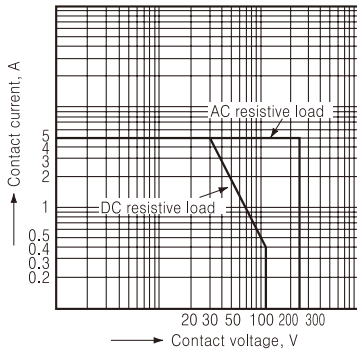

2. Life Curve

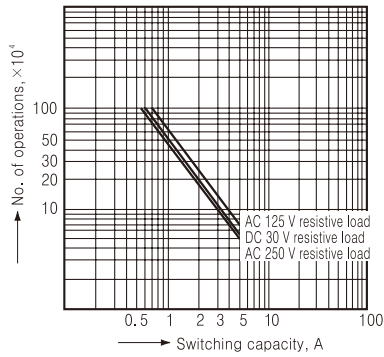

3. Operate & release time

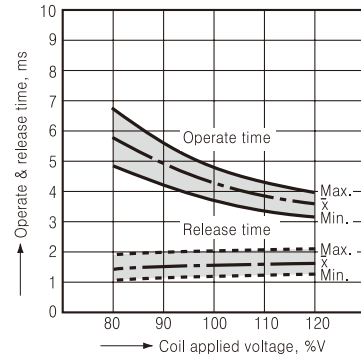

外观图

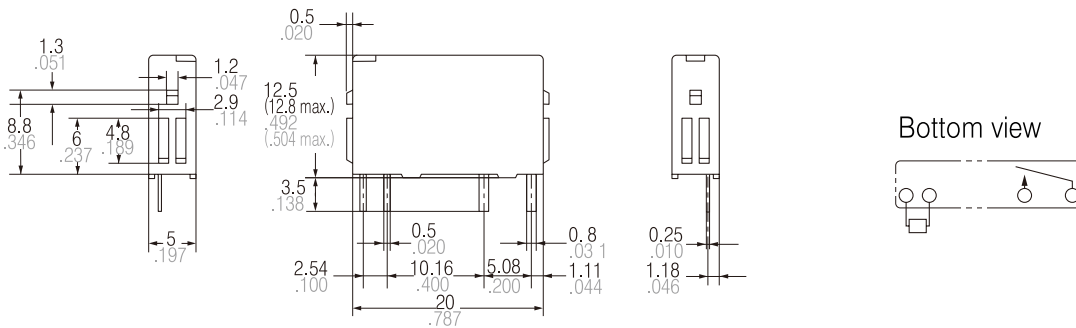

一般公差±0.3、±0.12